

Pump Model CPS 125-80-290

Speed 2900rpm

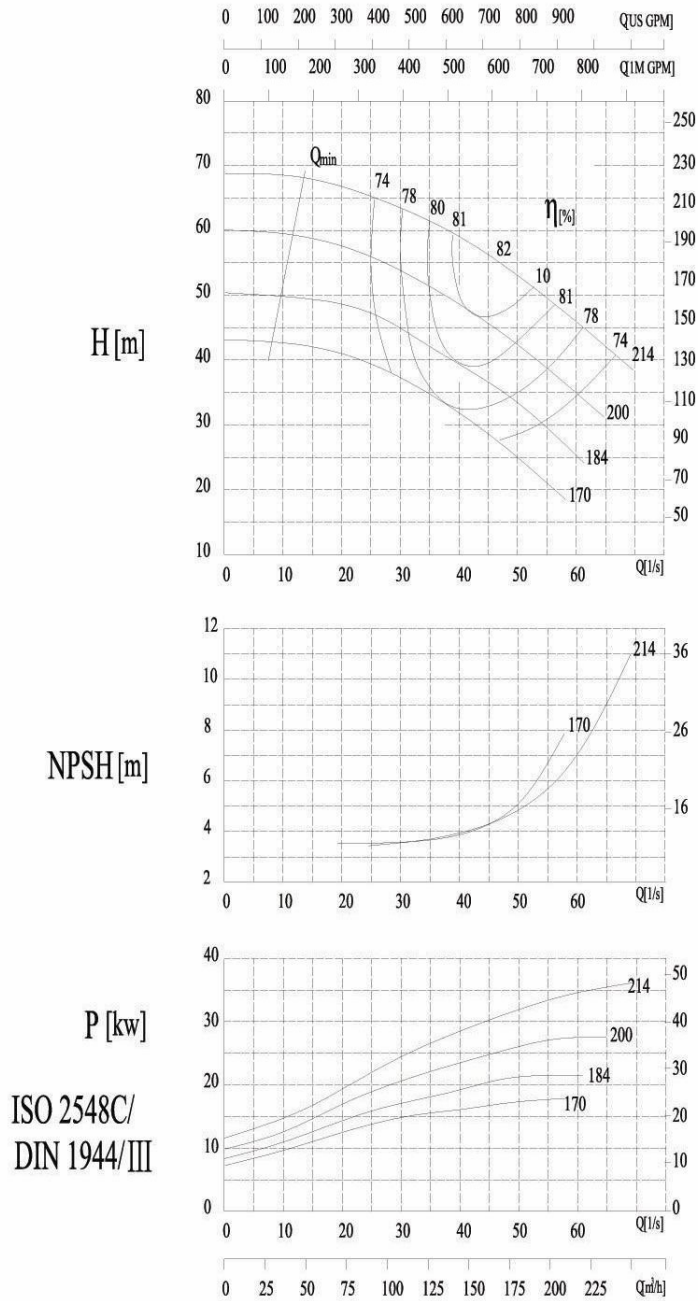

ISO 2548C/
DIN 1944/III

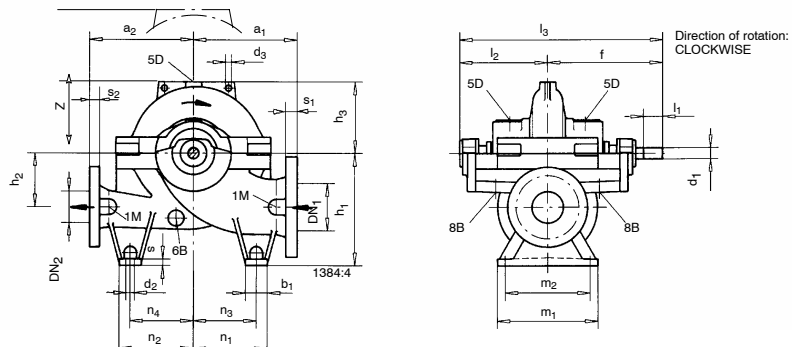

Pump Size	FLANGE DIMENSIONS				PUMP DIMENSIONS									
	DN1	DN2	s1	s2	a1	a2	d3	f	h1	h2	h3	l2	l3	z
CPS 125-80-210	125	80	34	29	300	300	19	415	315	140	168	300	715	340
	FOOT DIMENSIONS										SHAFT		PUMP WEIGHT	
	b1	d2	m1	m2	n1	n2	n3	n4	s	d1	L1	(kg)		
	70	18	320	270	205	205	170	170	20	35	80	186		